

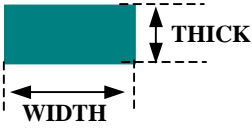

TECHNICAL DATA SHEET

PULTRUSION PROFILES

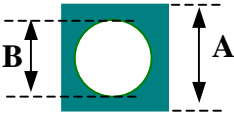

PROFILE	PICTURE	SIZES																								
RECTANGULAR FLATS		<ul style="list-style-type: none"> ➤ MAXIMUM AREA OF RECTANGULAR FLAT UPTO 2250 SQUARE MM ➤ THICKNESS FROM 3MM TO 40MM 																								
SQUARE TUBE		<table border="1" style="margin-left: auto; margin-right: auto;"> <thead> <tr> <th style="width: 50%;">A</th> <th style="width: 50%;">B(DIA)</th> </tr> </thead> <tbody> <tr> <td style="text-align: center;">40</td> <td style="text-align: center;">20</td> </tr> </tbody> </table>	A	B(DIA)	40	20																				
A	B(DIA)																									
40	20																									
RODS		<ul style="list-style-type: none"> ➤ RODS FROM DIA 6 - 50 MM 																								
CHANNELS		<table border="1" style="margin-left: auto; margin-right: auto;"> <thead> <tr> <th style="width: 33%;">A</th> <th style="width: 33%;">B</th> <th style="width: 33%;">C</th> </tr> </thead> <tbody> <tr><td style="text-align: center;">40</td><td style="text-align: center;">40</td><td style="text-align: center;">3</td></tr> <tr><td style="text-align: center;">40</td><td style="text-align: center;">40</td><td style="text-align: center;">4</td></tr> <tr><td style="text-align: center;">60</td><td style="text-align: center;">35</td><td style="text-align: center;">6</td></tr> <tr><td style="text-align: center;">75</td><td style="text-align: center;">30</td><td style="text-align: center;">4</td></tr> <tr><td style="text-align: center;">100</td><td style="text-align: center;">35</td><td style="text-align: center;">4</td></tr> <tr><td style="text-align: center;">100</td><td style="text-align: center;">50</td><td style="text-align: center;">6</td></tr> <tr><td style="text-align: center;">150</td><td style="text-align: center;">50</td><td style="text-align: center;">5</td></tr> </tbody> </table>	A	B	C	40	40	3	40	40	4	60	35	6	75	30	4	100	35	4	100	50	6	150	50	5
A	B	C																								
40	40	3																								
40	40	4																								
60	35	6																								
75	30	4																								
100	35	4																								
100	50	6																								
150	50	5																								
RECTANGULAR TUBES		<table border="1" style="margin-left: auto; margin-right: auto;"> <thead> <tr> <th style="width: 33%;">A</th> <th style="width: 33%;">B</th> <th style="width: 33%;">C</th> </tr> </thead> <tbody> <tr> <td style="text-align: center;">45</td> <td style="text-align: center;">22</td> <td style="text-align: center;">3</td> </tr> </tbody> </table>	A	B	C	45	22	3																		
A	B	C																								
45	22	3																								
I SECTION		<table border="1" style="margin-left: auto; margin-right: auto;"> <thead> <tr> <th style="width: 33%;">A</th> <th style="width: 33%;">B</th> <th style="width: 33%;">C</th> </tr> </thead> <tbody> <tr> <td style="text-align: center;">15</td> <td style="text-align: center;">30</td> <td style="text-align: center;">5</td> </tr> </tbody> </table>	A	B	C	15	30	5																		
A	B	C																								
15	30	5																								
L ANGLE		<table border="1" style="margin-left: auto; margin-right: auto;"> <thead> <tr> <th style="width: 50%;">A</th> <th style="width: 50%;">B</th> </tr> </thead> <tbody> <tr> <td style="text-align: center;">50</td> <td style="text-align: center;">4</td> </tr> <tr> <td style="text-align: center;">50</td> <td style="text-align: center;">6</td> </tr> <tr> <td style="text-align: center;">62</td> <td style="text-align: center;">6</td> </tr> </tbody> </table>	A	B	50	4	50	6	62	6																
A	B																									
50	4																									
50	6																									
62	6																									

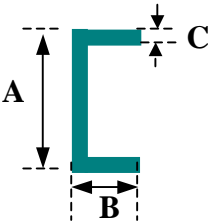
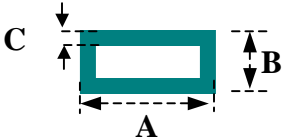
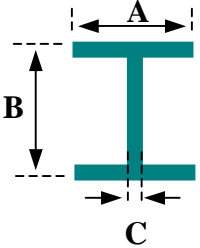
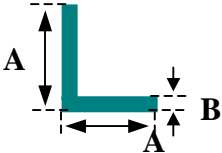

UNIGLASS INDUSTRIES PRIVATE LIMITED

Bangalore, India
info@uniglassindia.com
www.uniglassindia.com

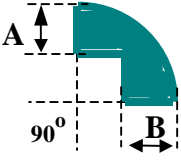
TECHNICAL DATA SHEET

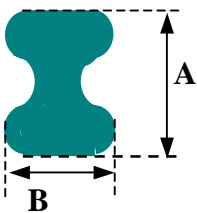
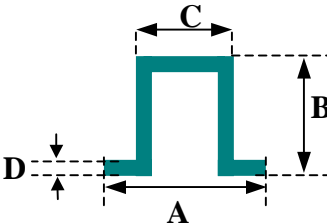
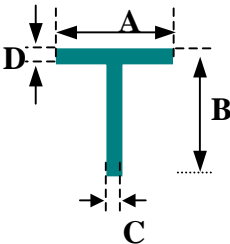
CORNER PIECE		<table border="1" style="width: 100%; border-collapse: collapse;"> <thead> <tr> <th style="width: 50%;">A</th> <th style="width: 50%;">C</th> </tr> </thead> <tbody> <tr><td>6</td><td>6</td></tr> <tr><td>8</td><td>8</td></tr> <tr><td>8</td><td>13</td></tr> <tr><td>13</td><td>13</td></tr> </tbody> </table>	A	C	6	6	8	8	8	13	13	13																								
A	C																																			
6	6																																			
8	8																																			
8	13																																			
13	13																																			
TUBES		<table border="1" style="width: 100%; border-collapse: collapse;"> <thead> <tr> <th style="width: 50%;">ID</th> <th style="width: 50%;">OD</th> </tr> </thead> <tbody> <tr><td>10</td><td>15.8</td></tr> <tr><td>14</td><td>21</td></tr> <tr><td>15</td><td>22</td></tr> <tr><td>16.6</td><td>22</td></tr> <tr><td>17.5</td><td>22</td></tr> <tr><td>20</td><td>24</td></tr> <tr><td>22</td><td>27</td></tr> <tr><td>26</td><td>32</td></tr> <tr><td>28</td><td>32</td></tr> <tr><td>28</td><td>33</td></tr> <tr><td>32</td><td>39</td></tr> <tr><td>35</td><td>41</td></tr> <tr><td>44.4</td><td>52</td></tr> <tr><td>52</td><td>60</td></tr> <tr><td>56</td><td>60</td></tr> <tr><td>67.5</td><td>73.5</td></tr> </tbody> </table>	ID	OD	10	15.8	14	21	15	22	16.6	22	17.5	22	20	24	22	27	26	32	28	32	28	33	32	39	35	41	44.4	52	52	60	56	60	67.5	73.5
ID	OD																																			
10	15.8																																			
14	21																																			
15	22																																			
16.6	22																																			
17.5	22																																			
20	24																																			
22	27																																			
26	32																																			
28	32																																			
28	33																																			
32	39																																			
35	41																																			
44.4	52																																			
52	60																																			
56	60																																			
67.5	73.5																																			
DOG BONES		<table border="1" style="width: 100%; border-collapse: collapse;"> <thead> <tr> <th style="width: 50%;">A</th> <th style="width: 50%;">B</th> </tr> </thead> <tbody> <tr><td>10</td><td>8</td></tr> <tr><td>12</td><td>10</td></tr> <tr><td>13</td><td>10</td></tr> <tr><td>16</td><td>10</td></tr> <tr><td>19</td><td>12</td></tr> <tr><td>25</td><td>16</td></tr> </tbody> </table>	A	B	10	8	12	10	13	10	16	10	19	12	25	16																				
A	B																																			
10	8																																			
12	10																																			
13	10																																			
16	10																																			
19	12																																			
25	16																																			
HAT PROFILES		<table border="1" style="width: 100%; border-collapse: collapse;"> <thead> <tr> <th style="width: 25%;">A</th> <th style="width: 25%;">B</th> <th style="width: 25%;">C</th> <th style="width: 25%;">D</th> </tr> </thead> <tbody> <tr><td>24.5</td><td>14</td><td>14.7</td><td>2.7</td></tr> <tr><td>24.5</td><td>18</td><td>14.7</td><td>2.7</td></tr> <tr><td>24.5</td><td>24</td><td>14.7</td><td>2.7</td></tr> </tbody> </table>	A	B	C	D	24.5	14	14.7	2.7	24.5	18	14.7	2.7	24.5	24	14.7	2.7																		
A	B	C	D																																	
24.5	14	14.7	2.7																																	
24.5	18	14.7	2.7																																	
24.5	24	14.7	2.7																																	
T SECTION		<table border="1" style="width: 100%; border-collapse: collapse;"> <thead> <tr> <th style="width: 25%;">A</th> <th style="width: 25%;">B</th> <th style="width: 25%;">C</th> <th style="width: 25%;">D</th> </tr> </thead> <tbody> <tr><td>15</td><td>30</td><td>5</td><td>5</td></tr> <tr><td>40</td><td>50</td><td>15</td><td>10.6</td></tr> </tbody> </table>	A	B	C	D	15	30	5	5	40	50	15	10.6																						
A	B	C	D																																	
15	30	5	5																																	
40	50	15	10.6																																	



UNIGLASS INDUSTRIES PRIVATE LIMITED

Bangalore, India
info@uniglassindia.com
www.uniglassindia.com

TECHNICAL DATA SHEET

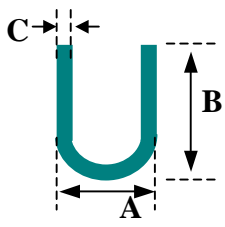
U SECTION		A	B	C
		20	38	5

Note:

1. Custom made profiles for the shapes required can also be provided
2. All measurements of length are in mm
3. All measurements of weight are in kg



UNIGLASS INDUSTRIES PRIVATE LIMITED

Bangalore, India
info@uniglassindia.com
www.uniglassindia.com